

ENGLISH

User manual



TABLE OF CONTENTS

1. SAFETY PRECAUTIONS AND PROCEDURES	2
1.1 Preliminary instructions	2
1.2 During use	3
1.3 After use	3
1.4 Overvoltage categories - definitions	3
2 GENERAL DESCRIPTION	4
2.1 Introduction.....	4
2.2 Functions.....	4
3 PREPARATION FOR USE	5
3.1 Preliminary checks	5
3.2 Power supply.....	5
3.3 Storage.....	5
4 OPERATING INSTRUCTIONS.....	6
4.1 Instrument description	6
4.2 Keyboard	6
5 INITIAL SETTINGS	6
5.1 Date, Time and Measuring Interval	6
6 OPERATIVE INSTRUCTIONS	7
6.1 Using the instrument in a Single Phase system	7
6.2 Using the instrument in a Three Phase 4-wires system	9
6.3 Using the instrument in a Three Phase 3-wires system	11
7 LED MESSAGE DESCRIPTION	13
8 CONNECTION OF INSTRUMENT TO PC	13
9 MAINTENANCE	14
9.1 General information	14
9.2 Battery replacement	14
9.3 Cleaning	14
9.4 End of life	14
10 TECHNICAL SPECIFICATIONS	15
10.1 Characteristics.....	15
10.1.1 Reference guidelines	15
10.1.2 General data	15
10.2 Environmental conditions	15
10.2.1 Climatic conditions	15
10.3 Standard accessories	16
10.1 Optional accessories	16
11 SERVICE	17
11.1 Warranty conditions.....	17
11.2 After-sale service.....	17

1. SAFETY PRECAUTIONS AND PROCEDURES

This instrument has been designed in compliance with IEC/EN61010-1 directive. For your own safety and to avoid damaging the instrument we suggest you follow the procedures hereby prescribed and read carefully all the notes preceded by the symbol ⚠.



CAUTION

Should you fail to keep to the prescribed instructions you could damage the instrument and/or its components or endanger your safety.

Take extreme care of the following conditions while taking measurements:

- Do not use the instrument in presence of explosive gas (material), combustible gas (material), steam or dust.
- Do not touch the circuit under test even though you are not taking measurements.
- Do not use the instrument if it seems to be malfunctioning (i.e. if you notice deformations, breaks, leakage of substances and so on).

The below symbols are used:



Caution: refer to the instruction manual; an improper use may damage the instrument or its components



Dangerous high voltage: risk of electrical shocks



Double insulated instrument



AC voltage and current

1.1 PRELIMINARY INSTRUCTIONS

- It can be used for **VOLTAGE** measurements up to 600V AC on installations with overvoltage category CAT III 600V~ between inputs and ground.
- Please use the standard safety precautions aimed at:
 - Protecting you against dangerous electric currents.
 - Protecting the instrument against incorrect operations.
 - Do not test circuits exceeding the voltage limits.
- If possible de-energize the plant under test before connecting the instrument. Take all safety precautions before taking actions on the plant.
- Do not perform any test under environmental conditions exceeding the limits indicated in this manual (see § 10.2)
- Make sure that batteries are correctly installed.
- Only the accessories supplied with the instrument guarantee compliance with the safety standards. They must be under good conditions and must be replaced, if necessary, with identical models.

1.2 DURING USE

Carefully read the below recommendations and instructions:



CAUTION

- No compliance with warnings and/or instructions may cause damage to the tester or its components or injure the operator
- During a measurement never touch any unused terminal.

1.3 AFTER USE

- If you expect not to use the instrument for a long period of time remove the batteries and strictly follow the indications at § 9.2.

1.4 OVERVOLTAGE CATEGORIES - DEFINITIONS

IEC/EN61010-1 (Safety requirements for electrical equipment for measurement, control and laboratory use, Part 1: General requirements) defines what a measurement category (usually called “overvoltage category”) is. At § 6.7.4: Measuring circuits you read:

(OMISSIS)

Circuits are divided into the following measurement categories:

- **Measurement category IV** is for measurements performed at the source of low voltage installations.
Examples are electricity instruments and measurements on primary overcurrent protection devices and ripple control units.
- **Measurement category III** is for measurements performed in the building installation
Examples are measurements on distribution boards, circuit breakers, wiring, including cables, bus-bars, junction boxes, switches, socket-outlets in the fixed installation, and equipment for industrial use and some other equipment, for example, stationary motors with permanent connection to fixed installation.
- **Measurement category II** is for measurements performed on circuits directly connected to the low voltage installation.
Examples are measurements on household appliances, portable tools and similar equipment.
- **Measurement category I** is for measurements performed on circuits not directly connected to MAINS
Examples are measurements on circuits not derived from MAINS, and specially protected (internal) MAINS-derived circuits. In the latter case, transient stresses are variable; for that reason, the norm requires that the transient withstanding capability of the equipment is made known to the user.

2 GENERAL DESCRIPTION

2.1 INTRODUCTION

The instrument was designed to grant the user the utmost safety conditions thanks to a new concept assuring double insulation and overvoltage CAT III 600V~ between inputs and to ground.

2.2 FUNCTIONS

This manual is referred to two models: **XL423** and **XL423**. Where not expressly indicated the characteristics are common for both models. XL423 can recording a **single voltage** in single-phase or three-phase plant. XL424 can recording up to **3 voltages** simultaneously in single-phase or three-phase plant.

The instrument can monitor a plant for a long time thanks to a sophisticated memory-managing algorithms. More exactly, the instrument uses the following sampling periods:

Measuring Interval	XL423 – Autonomy (days)	XL424 – Autonomy (days)
1s	5	1.5
6s	34	8
30s	170	42
1min	364 (*)	91
5min	1820 (*)	455 (*)

(*) Depending on batteries autonomy

The instrument starts each recording using the Measuring Interval set through PC management software (see § 8). Just before the event of full memory, the instrument applies the successive measuring interval to all the memory, thus getting more free memory locations. The instrument continues storing data according to the new sampling period.

3 PREPARATION FOR USE

3.1 PRELIMINARY CHECKS

This instrument has been checked mechanically and electrically before shipment. All precautions have been taken to assure that the instrument reaches you under perfect conditions. However, it is advisable to carry out a rapid check in order to detect any possible damage, which might have occurred during transport. Check the accessories contained in the packaging to make sure they are the same as reported in § 11.

3.2 POWER SUPPLY

The instrument is powered by 2x1.5V type AA LR06 alkaline batteries. For battery replacement please follow procedure described at § 9.2.



CAUTION

- After replacing batteries the instrument remains ON also if STATUS and ALARM LED are OFF. Pressing **START/STOP** key you activate or disable recordings only.
- During a recording the blinking ALARM LED every 3 seconds means a low battery status.

3.3 STORAGE

In order to guarantee the accuracy of measurements, after a period of storage under extreme environmental conditions wait until the instrument stabilizes within the listed operating conditions (see § 10.2).

4 OPERATING INSTRUCTIONS

4.1 INSTRUMENT DESCRIPTION

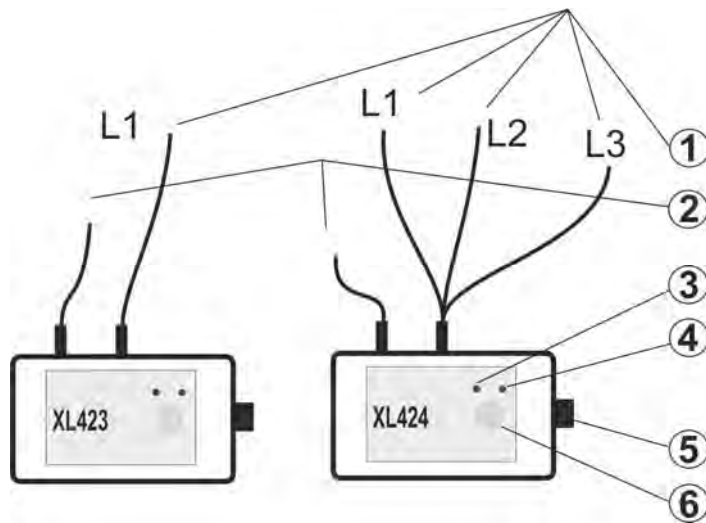

CAPTION:

1. Phase voltage Inputs
2. COM input
3. "STATUS" LED
4. "ALARM" LED
5. RS232 port
6. **START/STOP** key

Fig. 1: Instrument description

4.2 KEYBOARD

LED "STATUS" blinks every time the **START/STOP** key is pressed.

5 INITIAL SETTINGS

5.1 DATE, TIME AND MEASURING INTERVAL

It's possible to set measuring interval as well as date and time by using the management software. This program enables to:

- Set the measuring interval
- Control data and time of the instrument's internal clock
- Set instrument date and time.
- Check battery status

How to operate:

1. Connect the instrument to PC COM using included serial cable.
2. Run **TopView** software and open the "**PC-Instrument Connection**" section
3. Perform the detection of the instrument by using the "**Find the instrument**" or "**Autoset**" keys
4. Select the "**Configure the instrument**" command and press the "**Next**" key in order to set date/time in the instrument and the measurement interval in the "**Integrated Period**" field selecting values **1s, 6s, 30s, 1min or 5min**
5. Confirm with "**Send**" command.



CAUTION

- The instrument could keep the data stored even without batteries
- The set date and time don't get lost provided that the battery replacement takes less than 2 minutes.

6 OPERATIVE INSTRUCTIONS

6.1 USING THE INSTRUMENT IN A SINGLE PHASE SYSTEM



CAUTION

The Instrument can be used on installation with overvoltage CAT III 600V~ between the inputs and to ground. Do not attempt to take any voltage measurement exceeding the limits indicated in this manual. Exceeding the limits could cause electrical shock or damage to the instrument.

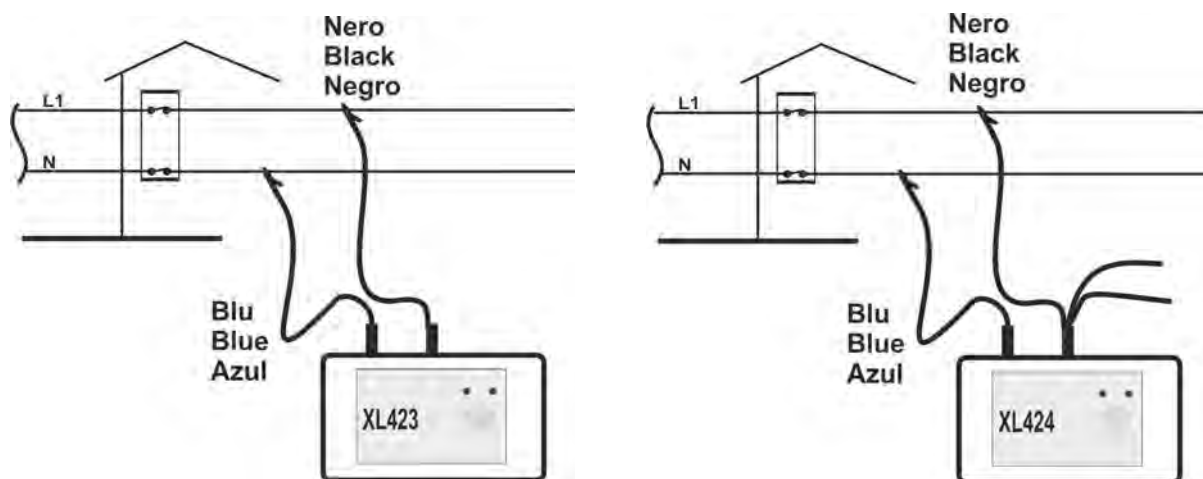

Fig. 2: Instrument's connection in single phase system



CAUTION

De-energize the plant under test before connecting the instrument. Take all the safety precautions before taking actions on the plant.

1. De-energize the plant under test before connecting the instrument.
2. Insert alligator clips in the safety banana test leads.
3. Connecting alligator clips in the plant as indicated in Fig. 2.
4. Re-energize the plant under test.
5. **How to start a Recording:**
 - If no recording was performed or if the recording data had been already downloaded to a PC, press the **START/STOP** key for 3 seconds. The STATUS LED will be blinking for the same time, then light will become stable for 1 second and the instrument will start the recording
 - If the recording data had not been already downloaded to a PC **and the operator wants to overwrite these data**, press the **START/STOP** key for 6 seconds. The STATUS LED will be quickly blinking during the key pressing for the same time, then the LED will become stable for 1 second and the instrument will start the recording. **The old recording will be deleted and overwritten by the new one.** The instrument will wait for the next minute beginning (second=00) and the STATUS LED will get a double blinking. After that the recording starts and the STATUS LED will blink every 3 seconds. The instrument is storing the data.

6. During a Recording:

- A 3 seconds blinking of STATUS LED means that the recording is active and the instrument is storing the data.
- A 3 seconds blinking of ALARM LED means that the batteries are low. During a recording any RS232 communication is possible.
- **During Recording operations RS-232 serial communications to PC are not possible.**

7. Stop a Recording:

- To stop a Recording press **START/STOP** key and keep it pressed for 3 seconds. The STATUS LED will quickly blink three times and the instrument will stop recording and then stop blinking.

For more details about blinking of STATUS and ALARM LED meanings, please refer to the § 7.

6.2 USING THE INSTRUMENT IN A THREE PHASE 4-WIRES SYSTEM

CAUTION



The Instrument can be used on installations with overvoltage CAT III 600V~ between the inputs and to ground. Do not attempt to take any voltage measurements exceeding the limits indicated in this manual. Exceeding the limits could cause electrical shock or damage to the instrument.

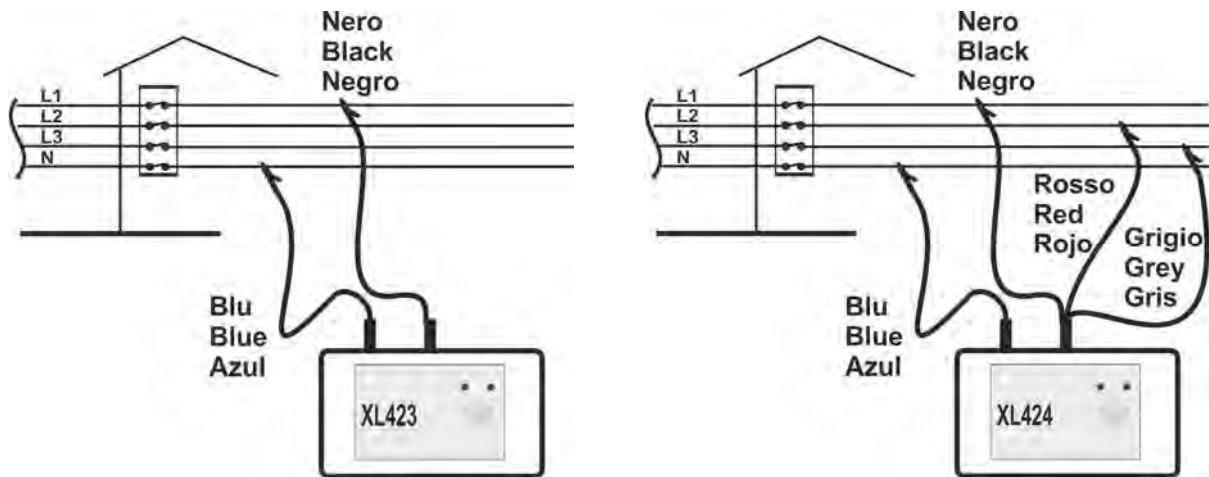

Fig. 3: Instrument's connection in three phase 4-wires system

CAUTION



De-energize the plant under test before connecting the instrument. Take all safety precautions before taking actions on the system.

1. De-energize the plant under test before connecting the instrument.
2. Inserting alligator clips in the safety banana test leads.
3. Connecting alligator clips to the plant as indicated in Fig. 3.
4. Re-energize the plant under test .
5. **How to start a Recording:**
 - If no recording was performed or if the recording data had been already downloaded to a PC, press **START/STOP** key for 3 seconds. The STATUS LED will be lighting for the same time, then will become stable for 1 second and the instrument will start recording
 - If the recording data had not been already downloaded to a PC **and the operator wants to overwrite these data**, press the **START/STOP** key for 6 seconds. The STATUS LED will be quickly blinking for the same time during key pressing, then the LED will become stable for 1 second and the instrument will start recording. **The old recording will be deleted and overwritten by the new one.** The instrument will wait for the next minute beginning (second=00) and the STATUS LED will double blink. After that the recording will start and the STATUS LED will blink every 3 seconds. The instrument will store the data.

6. During a Recording:

- A 3 seconds blinking of STATUS LED means that the recording is active and the instrument is storing data.
- A 3 seconds blinking of ALARM LED means that the batteries are low. During a recording any RS232 communication is possible.
- **During Recording operations RS-232 serial communications to PC are not possible.**

7. Stop a Recording:

- To stop a Recording press **START/STOP** key and keep it pressed for 3 seconds. The STATUS LED will quickly blink three times and the instrument will stop the recording and then stop blinking.

For more details about the blinking of STATUS and ALARM LED meanings, please refer to the § 7.

6.3 USING THE INSTRUMENT IN A THREE PHASE 3-WIRES SYSTEM

CAUTION



The Instrument can be used on installation with overvoltage CAT III 600V~ between the inputs and to ground. Do not attempt to take any voltage measurement exceeding the limits indicated in this manual. Exceeding the limits could cause electrical shock or damage to the instrument.

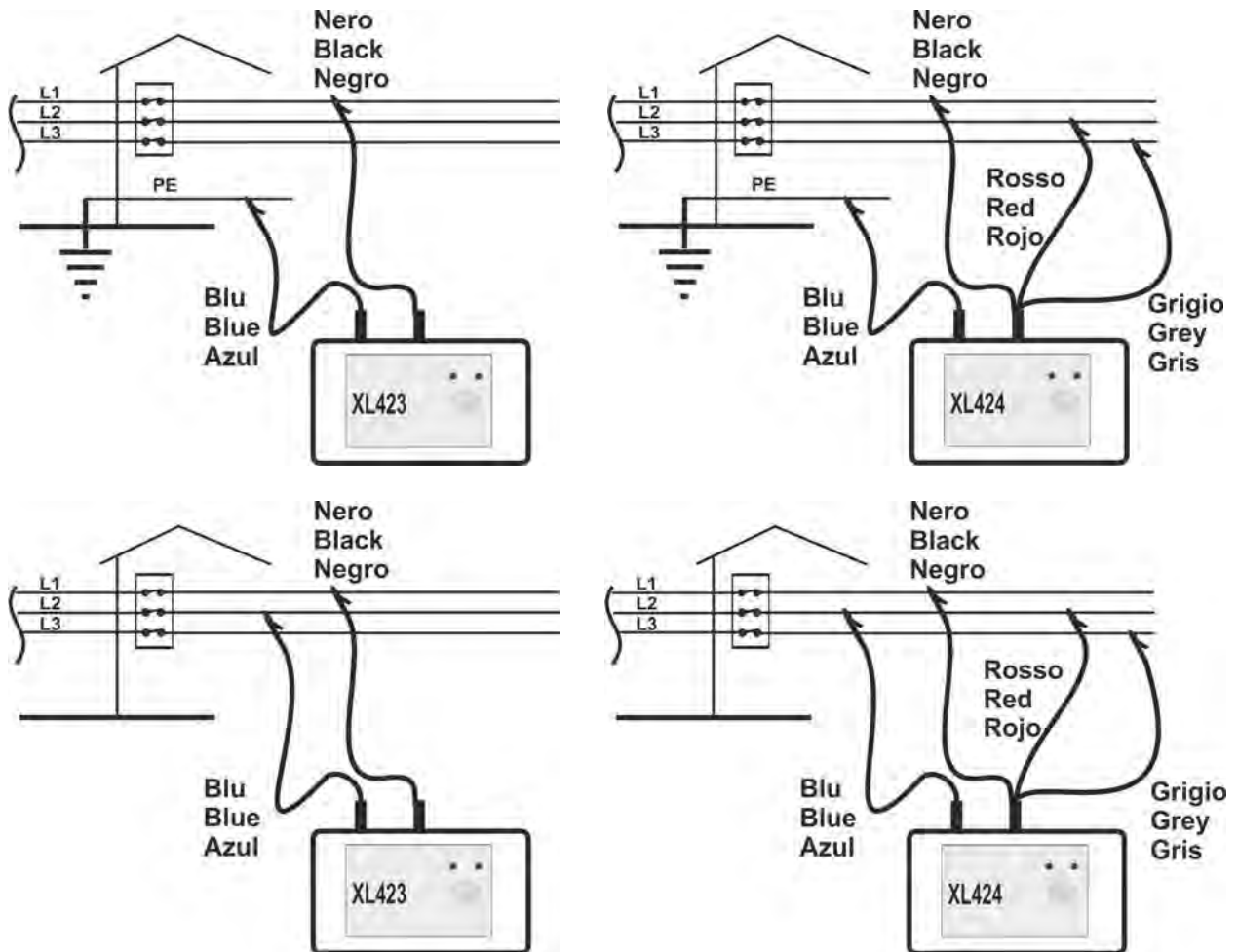

Fig. 4: Instrument's connection in three phase 3-wires plant

CAUTION



De-energize the plant under test before connecting the instrument. Take all safety precautions before taking actions on the system.

1. De-energize the plant under test before connecting the instrument.
2. Insert alligator clips into the safety banana test leads.
3. Connect alligator clips into the plant as indicated in Fig. 4.
4. Re-energize the plant under test.

5. How to start a Recording:

- If no recording was performed or if the recording data had been already downloaded to a PC, press the **START/STOP** key for 3 seconds. The STATUS LED will be lighting for the same time, than will become stable for 1 second and the instrument will start recording.
- If the recording data had not been already downloaded to a PC **and the operator wants to overwrite these data**, press the **START/STOP** key for 6 seconds. The STATUS LED will quickly blink for the same time during key pressing, then the LED will become stable for 1 second and the instrument will start recording. **The old recording will be deleted and overwritten by the new one.** The instrument will wait for the next minute beginning (second=00) and the STATUS LED will double blink. After that the recording starts and the STATUS LED will blink every 3 seconds. The instrument is storing the data.

6. During a Recording:

- A 3 seconds blinking of STATUS LED means that the recording is active and the instrument is storing the data.
- A 3 seconds blinking of ALARM LED means that the batteries are low. During a recording any RS232 communication is possible.
- **During Recording operations RS-232 serial communications to PC are not possible.**

7. Stop a Recording:

- To stop a Recording press **START/STOP** key and keep it pressed for 3 seconds. The STATUS LED will quickly blink three times and the instrument will stop the recording and then stop blinking.

For more details about blinking of STATUS and ALARM LED meanings, please refer to the § 7.

7 LED MESSAGE DESCRIPTION

For the STATUS and ALARM LED messages please refer to the following table:

LED	START/STOP Key	Light	Description
STATUS	Kept pressed 3 seconds at least	On for 1 second	Recording process correctly started. The previous recorded data were transferred to a PC
STATUS	Kept pressed 6 seconds at least	6 times blinking after 1 second on	Recording process correctly started. The previous recorded data were not transferred to a PC and were lost
STATUS	Not pressed	2 times blinking every 3 seconds	Waiting for the next minute (seconds=00)
STATUS	Not pressed	1 time blinking every 3 seconds	Recording in progress
STATUS	Pressed	3 times blinking	The recording process was stopped
ALARM	Not relevant	1 time blinking every 3 seconds	Low batteries. Stop the recording, transfer of data to a PC and replace batteries

8 CONNECTION OF INSTRUMENT TO PC

The connection of the instrument to a PC is possible through a serial cable supplied with the instrument. To download data to the PC (after installation of management software) keep to the below procedure:

1. Connect the serial cable to the instrument serial port and to a RS232 COM port of the PC.
2. Run **TopView** software and open the “**PC-Instrument Connection**” section
3. Perform the detection of the instrument by using the “**Find the instrument**” or “**Autoset**” keys
4. Select the “**Download data**” command and press the “**Next**” key



CAUTION

During Recording operations RS-232 serial communications to PC are not possible.

5. Select the recording and click on **Download** key to start download procedure. A dialogue box displays the recording stored in the instrument’s memory. By choosing the “**Download**” command the data transfer procedure will start.
6. At the end of the download the “Recording analysis” section will automatically start.

For more details see the HELP on line of TopView software

9 MAINTENANCE

9.1 GENERAL INFORMATION

This instrument is a precision instrument. Whether in use or in storage, please do not exceed the specifications to avoid any possible damage or danger during use. Do not place this instrument under high temperature and/or humidity or expose to direct sunlight. For long term storing, remove the batteries to avoid leakage of battery fluid that can damage the internal components.

9.2 BATTERY REPLACEMENT

A blinking of ALARM LED for 3 seconds means that the batteries are low. Stop the recording and replace the batteries with a new set. The management software allows the operator to verify the batteries' status.



CAUTION

The instrument could keep the data stored even without batteries. The set date and time don't get lost provided that the battery replacement takes less than 2 minutes.



CAUTION

Only experts and trained technicians should perform this operation. Remove the flexible head from the conductor under test before replacing the batteries.

1. Stop the recording (if necessary), remove the flexible heads from the conductors under test and transfer the stored data to a PC.
2. Remove the covers on the bottom side of the instrument using a screwdriver in the proper positions (1) and unscrew the 4 fixing screws (see Fig. 5).

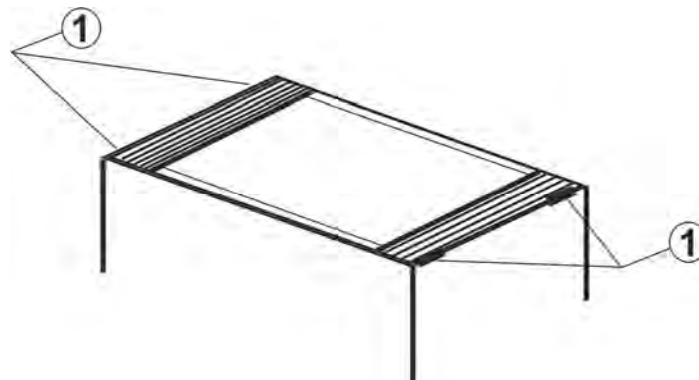

Fig. 5: Battery replacement

3. Open the box and unscrew the cover's fixing screw of the battery housing.
4. Replace the batteries with a new set of the same type (see § 10.1.2). Close the battery housing with the screw, reinsert the screws, screw them and reinsert the plastic covers.
5. Do not throw flat batteries in the environment after use.

9.3 CLEANING

To clean the instrument, use a soft dry cloth. Never use a wet cloth, solvents or water, etc.

9.4 END OF LIFE



CAUTION: this symbol indicates that equipment and its accessories shall be subject to a separate collection and correct disposal.

10 TECHNICAL SPECIFICATIONS

10.1 CHARACTERISTICS

Accuracy is calculated as $\pm [\%rdg + (dgt \cdot resolution)]$ referred to $23^{\circ}\text{C} \pm 5^{\circ}\text{C}$, $<60\%RH$.

AC TRMS VOLTAGE MEASUREMENT

Range	Resolution	Accuracy
0 ÷ 600V	0.1V	$\pm(1\%rdg + 2dgt)$

Note: The instrument will null readings lower than 2V

➤ Crest Factor max:	2
➤ Frequency (Hz):	50±6%, 60±6%
➤ Conversion mode:	TRMS
➤ Bandwidth:	3200Hz
➤ Sampling frequency:	64 samples each 20ms
➤ Memory size:	1Mbyte
➤ Sampling period:	1s, 6s, 30s, 1min, 5min
➤ Serial port:	RS232

10.1.1 Reference guidelines

Safety:	IEC/EN61010-1
EMC:	IEC/EN61326-1
Insulation:	double insulation
Pollution degree:	2
Measurement category:	CAT III 600V~ between inputs and to ground

10.1.2 General data

Mechanical characteristics

Dimensions (L x W xH):	120 x 80 x43mm (5 x 3 x 2in)
Test leads length:	approx 2.6m (7.5ft)
Weight (including batteries):	approx 0.5kg (1lv)
Protection index:	IP65 (RS232 connector Closed)

Power supply

Battery type:	2x1.5V alkaline type AA LR06
Battery life:	> 6 months (with charged batteries)

10.2 ENVIRONMENTAL CONDITIONS

10.2.1 Climatic conditions

Reference temperature:	$23^{\circ}\text{C} \pm 5^{\circ}\text{C}$ ($73^{\circ}\text{F} \pm 41^{\circ}\text{F}$)
Operating temperature:	$-20^{\circ}\text{C} \div 60^{\circ}\text{C}$ ($-4^{\circ}\text{F} \div 140^{\circ}\text{F}$)
Operating humidity:	100%RH (RS232 connector closed)
Storage temperature:	$-20^{\circ}\text{C} \div 60^{\circ}\text{C}$ ($-4^{\circ}\text{F} \div 140^{\circ}\text{F}$)
Storage humidity:	100%RH
Max height of use:	2000m (6562ft)

This instrument complies with the requirements of Low Voltage Directive 2014/35/EU (LVD) and of EMC Directive 2014/30/EU
This instrument complies with the requirements of 2011/65/EU (RoHS) directive and 2012/19/EU (WEEE) directive

10.3 STANDARD ACCESSORIES

Description	Code
Adhesive Velcro 50 x 70 cm	VELCRO
Set of 2 alligator clips B/B (<i>XL423 only</i>)	KITXL423C
Set of 4 alligator clips B/B/R/G (<i>XL424 only</i>)	KITXL424C
Management software + serial cable C2004	TOPVIEW2004
Carrying bag	BORSA2000
Batteries	
User manual	YAMUM0010HT0

10.1 OPTIONAL ACCESSORIES

Description	Code
RS-232/USB adapter	C2009

11 SERVICE

11.1 WARRANTY CONDITIONS

This equipment is guaranteed against any material fault or manufacturer's defect, in accordance with the general conditions of sale. During the warranty period (one year), faulty parts may be replaced, while the manufacturer reserves the right to decide either to repair or replace the product. In the event of returning the equipment to the after-sales service or to a regional branch, the transport charges are up to the customer. The returning must be agreed in advance with the supplier or local distributor. A report indicating the reasons for returning and defects detected must be joined to the instrument. The manufacturer will not be responsible for any damage against persons or things.

The warranty cannot be applied under the following circumstances:

- Accessories and batteries (not covered by warranty).
- Improper use of the equipment or combination of the instrument with incompatible equipment.
- Damages caused by incorrect shipping procedures.
- Damages caused by repair/service trials of unauthorized people.
- Modifications to the equipment without explicit authorization of our Technical Dept.
- Adaptation to a particular application not provided for by the definition of the equipment or by the instruction manual.

The contents of this manual may not be reproduced in any form whatsoever without prior agreement.

Our products are patented. The logotypes are registered. We reserve the right to modify characteristics and prices as part of technological developments which might be required.

11.2 AFTER-SALE SERVICE

If the equipment doesn't work properly please check the battery condition and replace them if necessary before contacting our Service Dept. If the problem persists check if your operating procedure complies with the one described in this manual.

In the event of returning the equipment to the after-sales service or to a regional branch, the shipping charges are up to the customer. The returning must be agreed in advance with the supplier or local distributor. A report indicating the reasons for returning and defects detected must be joined to the instrument. The manufacturer will not be responsible for any damage against persons or things.